



PP8H FOUR POST LIFT

More information please login
www.dinggaojx.cn
www.sxdinggao.en.alibaba.com

PRODUCT DESCRIPTION

- Vertical rise and fall parking lift, It is the ideal equipment for commercial vehicles and SUV medium and large vehicles parking, Lifting height 2185mm, lifting capacity 8000 lbs.
- Convenient installation, compact structure, the special mobile fitting make the whole device move convenient when no-load.
- Manual mechanical safety organ and wire rope fracture protective mechanism, double safety mechanism, more safety.
- It use high density slide blocks in the columns, Long service life.
- Explosion-proof throttle valve on the oil tube, It can prevent falling fast because of oil tube burst.
- The platform is made of high strength antiskid pattern plate overall molding.
- The special brake block can prevent the vehicles moving.
- Optional rolling jack, convenient for maintenance vehicles.



PP8H

FOUR POST LIFT



Technical parameters

Model	PP-8H
LxWxH	5249.5x2601x2476mm
Lifting Height	2185mm
Lifting Time	50s
Length of Columns	3995mm
Overall Length	5249.5mm
Inside Soleplate of Columns Width	2111mm
Overall Width	2601mm
Platform Length	4200mm
Lifting Capacity	(8000lbs)3600kg
Runway Width	475mm
Width Between Runway	954mm
Packing Size	4300x570x725mm
Gross Weight	840kg

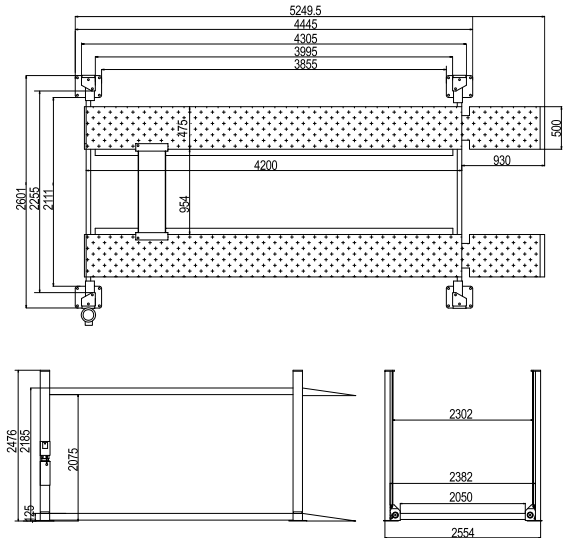

Detail



Multiplying pulley structure.



Explosion-proof valve.



Caster kit can make people move lift easy when no-load .



Up ramp with yellow slider can warn people and protect friction.



Safety mechanism for protect quickly declined cause by cable breakage.



Manual safety bar.

OPARICK

More information please login:
www.oparick.com www.sxdinggao.en.alibaba.com

SHAOXINGDINGGAOMECHANICALEQUIPMENT CO.,LTD.

NO.186 Mashan Road, Paojiang Industrial Zone, Shaoxing, Zhejiang,China
 TEL: 0086-0575-84623366 FAX: 0086-0575-84623331
 E-mail: lichao@dinggaomechanical.com



www.oparick.com



www.sxdinggao.en.alibaba.com



PP8HL FOUR POST LIFT

More information please login
www.dinggaojx.cn
www.sxdinggao.en.alibaba.com

PRODUCT DESCRIPTION

- Vertical rise and fall parking lift, It is the ideal equipment for commercial vehicles and SUV medium and large vehicles parking, Lifting height 2185mm, lifting capacity 8000 lbs.
- Convenient installation, compact structure, the special mobile fitting make the whole device move convenient when no-load.
- Manual mechanical safety organ and wire rope fracture protective mechanism, double safety mechanism, more safety.
- It use high density slide blocks in the columns, Long service life.
- Explosion-proof throttle valve on the oil tube. It can prevent falling fast because of oil tube burst.
- The platform is made of high strength antiskid pattern plate overall molding.
- The special brake block can prevent the vehicles moving.
- Optional rolling jack, convenient for maintenance vehicles.



PP8HL

FOUR POST LIFT



Technical parameters

Model	PP-8HL
LxWxH	5748.5x2974x2476mm
Lifting Height	2185mm
Lifting Time	70s
Length of Columns	4494mm
Overall Length	5748.5mm
Inside Soleplate of Columns Width	2221mm
Overall Width	2974mm
Platform Length	4699mm
Lifting Capacity	(8000lbs)3600kg
Runway Width	508mm
Width Between Runway	965mm
Packing Size	4800x570x725mm
Gross Weight	890kg

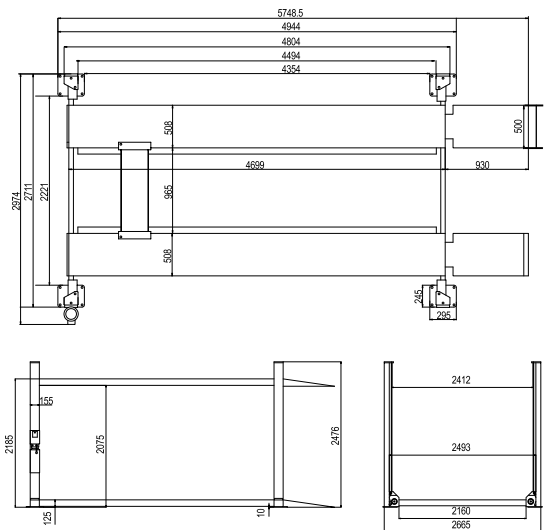

Detail



Explosion-proof valve.



Multiplying pulley structure.



Manual safety bar for release.



Safety mechanism for protect quickly declined caused by cable breakage.



Caster kit can make people move lift easy when no-load.



Up ramp with yellow slider can Warn people and protect friction.

OPARCK

More information please login:
www.oparck.com www.sxdinggao.en.alibaba.com

SHAOXINGDINGGAOMECHANICALEQUIPMENT CO., LTD.

NO.186 Mashan Road, Paojiang Industrial Zone, Shaoxing, Zhejiang, China
 TEL: 0086-0575-84623366 FAX: 0086-0575-84623331
 E-mail: lichao@dinggaomechanical.com



www.oparck.com



www.sxdinggao.en.alibaba.com



PP8S FOUR POST LIFT

More information please login
www.oparck.com
www.sxdinggao.en.alibaba.com

PRODUCT DESCRIPTION

- Vertical rise and fall parking lift , It is the ideal equipment for the ordinary vehicle parking Lifting height 1845mm, Lifting capacity 8000 lbs.
- Convenient installation, compact structure, the special mobile fitting make the whole device move convenient when no-load.
- Manual mechanical safety organ and wire rope fracture protective mechanism, double safety mechanism, more safety.
- It use high density slide blocks in the columns, Long service life.
- Explosion-proof throttle valve on the oil tube, It can prevent falling fast because of oil tube burst.
- The platform is made of high strength antiskid pattern plate overall molding.
- The special brake block can prevent the vehicles moving.
- Optional rolling jack, convenient for maintenance vehicles.



PP8S

FOUR POST LIFT



Technical parameters

Model	PP-8S
LxWxH	5249.5x2864x2076mm
Lifting Height	1845mm
Lifting Time	50s
Length of Columns	3995mm
Overall Length	5249.5mm
Inside Soleplate of Columns Width	2111mm
Overall Width	2864mm
Platform Length	4200mm
Lifting Capacity	(8000lbs)3600kg
Runway Width	475mm
Width Between Runway	954mm
Packing Size	4300x570x725mm
Gross Weight	780kg

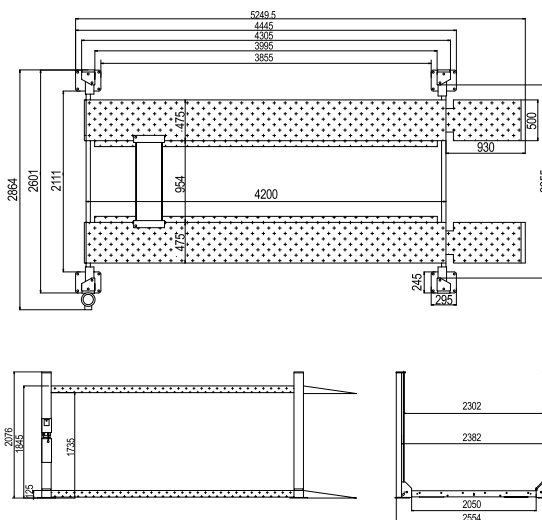

Detail



Oil cylinder with explosion-proof valve.



People move lift easy when no-load.



For safety mechanism protect quickly declined cause by wire rope breakage.



Up ramp with yellow slider can warn people and protect friction.



Cable connection under main platform.



Manual safety bar for release.

OPARCK

More information please login:
www.oparck.com www.sxdinggao.en.alibaba.com

SHAOXINGDINGGAOMECHANICALEQUIPMENT CO.,LTD.

NO.186 Mashan Road, Paojiang Industrial Zone, Shaoxing, Zhejiang, China
 TEL: 0086-0575-84623366 FAX: 0086-0575-84623331
 E-mail: lichao@dinggaomechanical.com



www.oparck.com



www.sxdinggao.en.alibaba.com



PP-8SW

DOUBLE PARKING GARAGE

More information please login
www.oparck.com
www.sxdinggao.en.alibaba.com

PRODUCT DESCRIPTION

- It is the ideal parking garage for vehicles, with a maximum lift of 1845 mm and a lifting capacity of 8,000 lbs.
- Manual safety mechanism and cable breaking protection mechanism, double safety mechanism, safer.
- Use high density slider, long service life.
- Explosion-proof throttle valve on tubing can prevent tubing from bursting and falling rapidly.
- Integral forming of platform with high strength anti-skid plate.
- Special brake block to prevent vehicle from moving.
- Four cars can be parked at the same time to save space.



PP-8SW

DOUBLE PARKING GARAGE



Technical parameters

Model	PP-8SW
LxWxH	5250x4617x2076mm
Lifting Height	1845mm
Lifting Time	50s
Length of Columns	3995mm
Overall Length	5250mm
Inside Soleplate of Columns Width	4127mm
Overall Width	4617mm
Platform Length	4200mm
Lifting Capacity	(8000lbs)3600kg
Runway Width	475mm
Width Between Runway	958mm
Packing Size1	4280x570x720mm
Packing Size2	4630x570x510mm
Gross Weight1	695kg
Gross Weight2	690kg

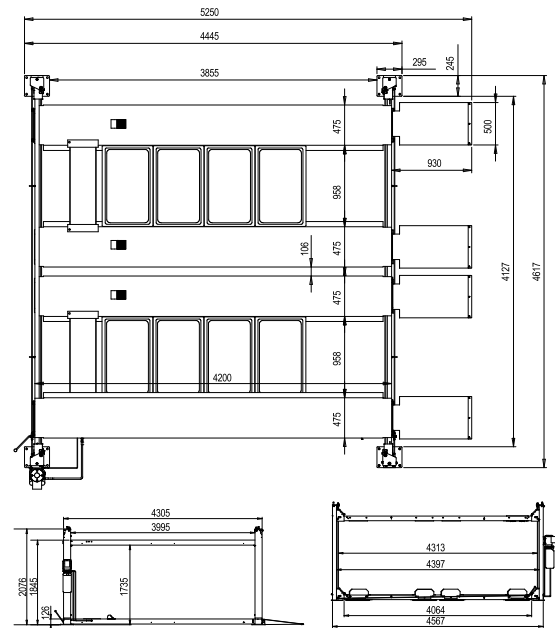

Detail



Up ramp with yellow slider can warn people and protect friction.



Manual release bar.

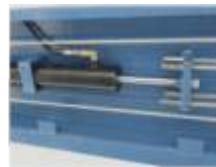

Hydraulic cylinder under runway with explosion-proof valve.



Safety mechanism for protect quickly declined cause by cable breakage.



The structure of cable and pulley under main runway.



Down limit switch.

OPARICK

More information please login:
www.oparck.com www.sxdinggao.en.alibaba.com

SHAOXINGDINGGAOMECHANICALEQUIPMENT CO., LTD.

NO.186 Mashan Road, Paojiang Industrial Zone, Shaoxing, Zhejiang, China
 TEL: 0086-0575-84623366 FAX: 0086-0575-84623331
 E-mail: lichao@dinggaomechanical.com



www.oparck.com



www.sxdinggao.en.alibaba.com



PP-9 FOUR POST LIFT

More information please login
www.oparck.com
www.sxdinggao.en.alibaba.com

PRODUCT DESCRIPTION

- Vertical rise and fall parking lift, It is the ideal equipment for weight within 9000 lbs vehicle parking, Lifting height 2150mm, Lifting capacity 9000 lbs.
- Convenient installation, compact structure, the special mobile fitting make the whole device move convenient when no-load.
- Manual mechanical safety organ and cable fracture protective mechanism, double safety mechanism, more safety.
- It use high density slide blocks in the columns, Long service life.
- Explosion-proof throttle valve on the oil tube, It can prevent falling fast because of oil tube burst.
- The platform is made of high strength antiskid pattern plate overall molding.
- The special brake block can prevent the vehicles moving.
- Optional rolling jack, convenient for maintenance vehicles.



PP-9

FOUR POST LIFT



Technical parameters

Model	PP-9
LxWxH	5782.5x3354x2456mm
Lifting Height	2150mm
Lifting Time	50s
Length of Columns	4693mm
Overall Length	5782.5mm
Inside Soleplate of Columns Width	2484mm
Overall Width	3354mm
Platform Length	4990mm
Lifting Capacity	(9000lbs)4000kg
Runway Width	508mm
Width Between Runway	994mm
Packing Size	5170x570x725mm
Gross Weight	1120kg

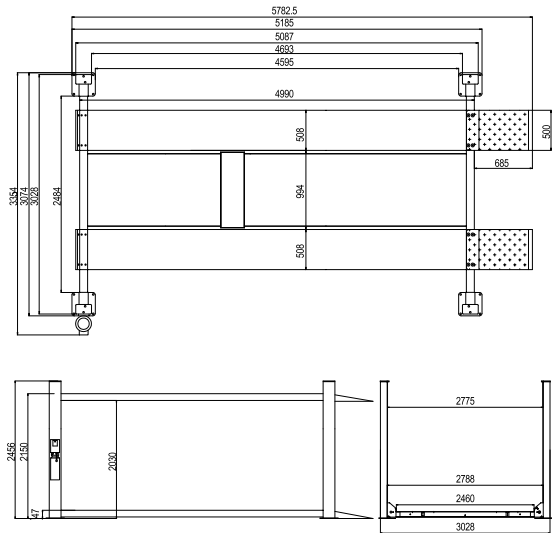

Detail



Cable and pulley under main platform.



Caster kit can make people move lift easy when no-load.



Manual safety bar for release.



Up ramp with yellow slider can warn people and protect friction.



Safety mechanism for protect quickly declined cause by cable breakage.



Nylon slide board for limit insurance piece.

OPARICK

More information please login:
www.oparck.com www.sxdinggao.en.alibaba.com

SHAOXINGDINGGAOMECHANICALEQUIPMENT CO., LTD.

NO.186 Mashan Road, Paojiang Industrial Zone, Shaoxing, Zhejiang, China
 TEL: 0086-0575-84623366 FAX: 0086-0575-84623331
 E-mail: lichao@dinggaomechanical.com



www.oparck.com



www.sxdinggao.en.alibaba.com



PP-9H

HIGH FOUR-COLUMN PARKING GARAGE

More information please login
www.oparck.com
www.sxdinggao.en.alibaba.com

PRODUCT DESCRIPTION

- Vertical rise and fall parking lift, It is the ideal equipment for commercial vehicles and SUV medium and large vehicles parking, Lifting height 3800mm, Lifting capacity 9000 lbs.
- Convenient installation, compact structure, the special mobile fitting make the whole device move convenient when no-load.
- Manual mechanical safety organ and wire rope fracture protective mechanism, double safety mechanism, more safety.
- It use high density slide blocks in the columns, Long service life.
- Explosion-proof throttle valve on the oil tube, It can prevent falling fast because of oil tube burst.
- The platform is made of high strength antiskid pattern plate overall molding.
- The special brake block can prevent the vehicles moving.
- Optional rolling jack, convenient for maintenance vehicles.



PP-9H

HIGH FOUR-COLUMN PARKING GARAGE



Technical parameters

Model	PP-9H
LxWxH	5786x2809x4322mm
Max Lifting Height	3800mm
Min. Height	147mm
Lifting Distance	3680mm
Lifting Time	50s
Length of Columns	4679mm
Overall Length	5786mm
Inside Soleplate of Columns Width	2219mm
Overall Width	2809mm
Platform Length	4990mm
Lifting Capacity	(9000lbs)4000kg
Runway Width	508mm
Width Between Runway	950-1140mm
Packing Size1	5170x570x720mm
Packing Size2	4010x200x130mm
Gross Weight1	1120kg
Gross Weight2	160kg

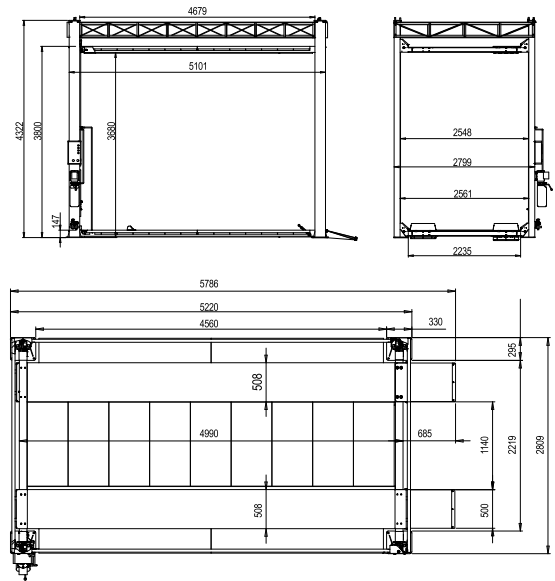

Detail



Limit switch.

Air cylinder for air release.

cable and pulley under main runway.

Oil cylinder with explosion-proof valve.

Oil-mist separator.

Under main runway valve.

OPARICK

More information please login:
www.oparick.com www.sxdinggao.en.alibaba.com

SHAOXINGDINGGAOMECHANICALEQUIPMENT CO., LTD.

NO.186 Mashan Road, Paojiang Industrial Zone, Shaoxing, Zhejiang, China
 TEL: 0086-0575-84623366 FAX: 0086-0575-84623331
 E-mail: lichao@dinggaomechanical.com



www.oparick.com



www.sxdinggao.en.alibaba.com



PP-9F FOUR POST LIFT

More information please login
www.oparck.com
www.sxdinggao.en.alibaba.com

PRODUCT DESCRIPTION

- The beam is formed by cold drawing with high strength steel.
- The platform is made of high-quality decorative plate.
- The manual mechanical self-resetting unlocking structure can adjust the unlocking lever according to the actual needs within the design range, the unlocking handle is equipped with a metal soft zipper that can be unlocked even at the highest position, which is safe and reliable.
- Each wire rope is provided with an insurance mechanism to prevent the equipment from falling when the wire rope is broken.
- Yellow warning parts on the slope at the same time of warning also protect the ground friction.
- The columns are made of high strength steel and are formed by cold drawing, each column has safety holes, which can be locked at any height within the design range.
- The equipment passed dynamic load test of 125% and static load test of 150%, and passed CE certification.
- Optional bolt type iron upper plate or plug-in type aluminum alloy upper plate.
- Each equipment is equipped with four sets of fast-installed mobile pulley set at the bottom of the four columns. Under the condition of no load, the equipment only needs two people to operate, so that the equipment can move freely on the flat ground.



PP-9F

FOUR POST LIFT



Technical parameters

Model	PP-9F
LxWxH	5330x2870x2312mm
Lifting Height	1914mm on lock
Lifting Time	50s
Length of Inside Columns	4066mm
Overall Length	5330mm
Inside Soleplate of Columns Width	2490mm
Overall Width	2870mm
Platform Length	4200mm
Lifting Capacity	(9000lbs)4000kg
Runway Width	475mm
Width Between Runway	964mm
Packing Size	4250x570x730mm
Gross Weight	890kg

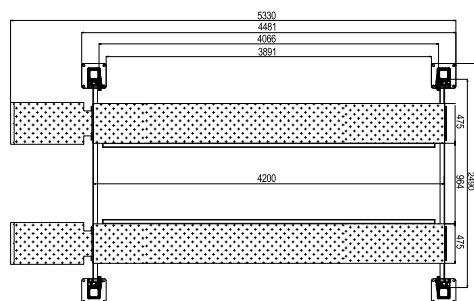
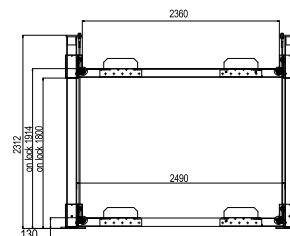

Detail



Caster kit can make people move lift easy when no-load.



Safety mechanism for protect quickly declined cause by cable breakage.



Manual safety bar for release.



Oil cylinder with explosion-proof valve.



Cable and pulley under main platform.



Cable connection under main platform.

OPARCK

More information please login:
www.oparck.com www.sxdinggao.en.alibaba.com

SHAOXINGDINGGAOMECHANICAL EQUIPMENT CO., LTD.

NO.186 Mashan Road, Paojiang Industrial Zone, Shaoxing, Zhejiang, China
 TEL: 0086-0575-84623366 FAX: 0086-0575-84623331
 E-mail: lichao@dinggaomechanical.com



www.oparck.com



www.sxdinggao.en.alibaba.com



PP-9XLT

FOUR POST LIFT

More information please login
www.oparck.com
www.sxdinggao.en.alibaba.com

PRODUCT DESCRIPTION

- The beam is formed by cold drawing with high strength steel.
- The platform is made of high-quality decorative plate.
- The manual mechanical self-resetting unlocking structure can adjust the unlocking lever according to the actual needs within the design range. The unlocking handle is equipped with a metal soft zipper that can be unlocked even at the highest position, which is safe and reliable.
- Each wire rope is provided with an insurance mechanism to prevent the equipment from falling when the wire rope is broken.
- Yellow warning parts on the slope at the same time of warning also protect the ground friction.
- The columns are made of high strength steel and are formed by cold drawing. Each column has safety holes, which can be locked at any height within the design range.
- The equipment passed dynamic load test of 125% and static load test of 150%, and passed CE certification.
- Optional bolt type iron upper plate or plug-in type aluminum alloy upper plate.
- Each equipment is equipped with four sets of fast-installed mobile pulley set at the bottom of the four columns. Under the condition of no load, the equipment only needs two people to operate, so that the equipment can move freely on the flat ground.



PP-9XLT

FOUR POST LIFT



Technical parameters

Model	PP-9XLT
LxWxH	5952x2870x2516mm
Lifting Height	2119mm on lock
Lifting Time	50s
Length of Inside Columns	4688mm
Overall Length	5952mm
Inside Soleplate of Columns Width	2490mm
Overall Width	2870mm
Platform Length	4822mm
Lifting Capacity	(9000lbs)4000kg
Runway Width	475mm
Width Between Runway	964mm
Packing Size	4900x570x730mm
Gross Weight	1136kg

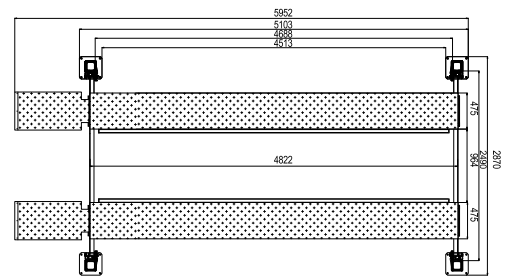
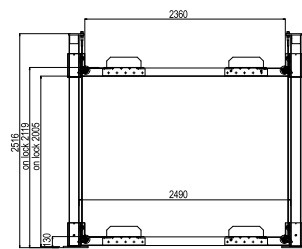

Detail



Caster kit can make people move lift easy when no-load. Safety mechanism for protect quickly declined cause by cable breakage. Manual safety bar for release. Oil cylinder with explosion-proof valve. Cable and pulley under main platform. Cable connection under main platform.

OPARICK

SHAOXINGDINGGAOMECHANICALEQUIPMENT CO., LTD.

NO.186 Mashan Road, Paojiang Industrial Zone, Shaoxing, Zhejiang, China
 TEL: 0086-0575-84623366 FAX: 0086-0575-84623331
 E-mail: lichao@dinggaomechanical.com



www.oparick.com



www.sxdinggao.en.alibaba.com

More information please login:
www.oparick.com www.sxdinggao.en.alibaba.com



PP-11FW

DOUBLE PARKING GARAGE

More information please login
www.oparck.com
www.sxdinggao.en.alibaba.com

PRODUCT DESCRIPTION

- It is the ideal parking garage for vehicles, with a maximum lift of 1927mm and a lifting capacity of 11,000lbs.
- Manual safety mechanism and cable breaking protection mechanism, double safety mechanism, safer.
- Use high density slider, long service life.
- Explosion-proof throttle valve on tubing can prevent tubing from bursting and falling rapidly.
- Integral forming of platform with high strength anti-skid plate.
- Special brake block to prevent vehicle from moving.
- Four cars can be parked at the same time to save space.



PP-11FW

DOUBLE PARKING GARAGE



技术参数 Technical parameters

型号	Model	PP-11FW
长×宽×高	LxWxH	5584.83x5033x2312mm
举升高度	Lifting Height	1927mm
举升时间	Lifting Time	50s
柱间宽	Length of Columns	4523mm
总长度	Overall Length	5584.83mm
总宽度	Overall Width	5033mm
平台长度	Platform Length	4200mm
载重量	Lifting Capacity	11000LBS
跑道宽度	Runway Width	475mm
跑道间宽度	Width Between Runway	955mm
包装尺寸1	Packing Size1	4280x570x720mm
包装尺寸2	Packing Size2	5000x570x510mm
毛重1	Gross Weight1	695kg
毛重2	Gross Weight2	690kg

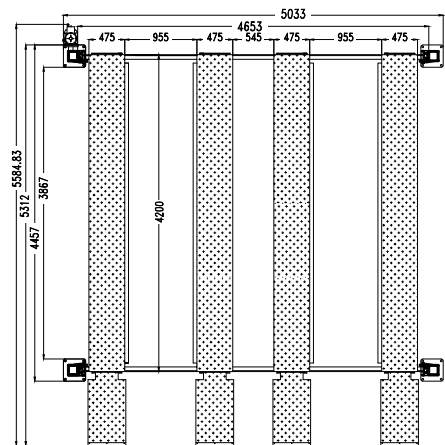
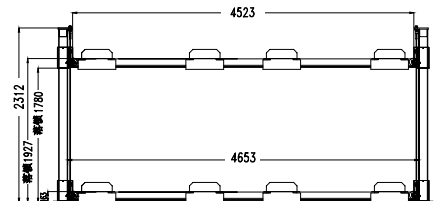

细节说明 Detail



Up ramp with yellow slider can warn people and protect friction.



Column safety mechanism



Hydraulic cylinder under runway with explosion-proof valve.



Mechanical unlocking device



The structure of cable and pulley under main runway.



Oil-receiving tray

OPARCK

More information please login:
www.oparck.com www.sxdinggao.en.alibaba.com

SHAOXINGDINGGAOMECHANICAL EQUIPMENT CO., LTD.

NO.186 Mashan Road, Paojiang Industrial Zone, Shaoxing, Zhejiang, China
 TEL: 0086-0575-84623366 FAX: 0086-0575-84623331
 E-mail: lichao@sxdinggao.com



www.oparck.com



www.sxdinggao.en.alibaba.com



PP-8SU

FOUR POST PARKING GARAGE LIFT

More information please login
www.oparck.com
www.sxdinggao.en.alibaba.com

PRODUCT DESCRIPTION

- Beautiful appearance, save space
- Motor drive oil pump drive hydraulic cylinder, wire rope drive, quiet working environment
- Mechanical safety lock, can be arbitrarily locked in the design range of the height of the operation, safe and reliable
- The levelness of the four angles in the locked position can be adjusted
- A set of throttle valves is installed in the oil circuit



PP-8SU

FOUR POST PARKING GARAGE LIFT



技术参数 Technical parameters

Model	PP-8SU
Capacity	3600KG
Max. Lifting Height (upper platform)	1987mm
Lifting time	50s
Min Height	189mm
Overall length	5178mm
Inside column width	2675.5mm

技术参数 Technical parameters

Model	PP-8SU
Overall Width	2857.5mm
Platform Length	5000mm
Runway Width	2212mm
Width between runway	1121mm
Platform capacity	3600KG

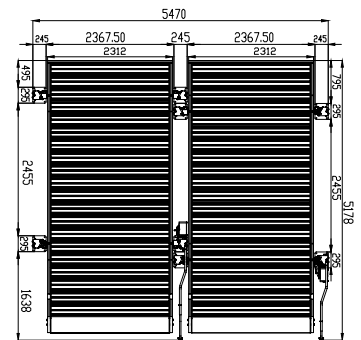
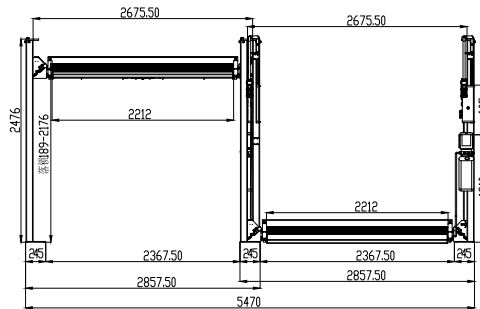
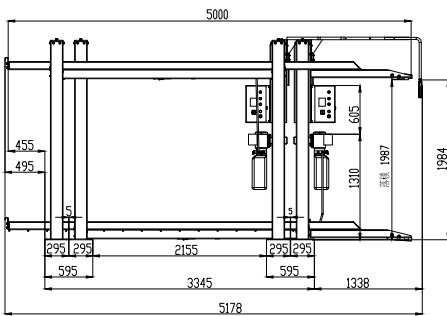

细节说明 Detail



Electronic control



Upper limit switch



Wave plate for vehicle loading



The structure of cable and pulley under main runway.



Lifting switch

OPARCK

More information please login:
www.oparck.com www.sxdinggao.en.alibaba.com

SHAOXINGDINGGAOMECHANICAL EQUIPMENT CO., LTD.

NO.186 Mashan Road, Paojiang Industrial Zone, Shaoxing, Zhejiang, China
TEL: 0086-0575-84623366 FAX: 0086-0575-84623331
E-mail: lichao@dinggao.com



www.oparck.com



www.sxdinggao.en.alibaba.com



PP-17DH MULTI-LEVEL PARKING LIFT

More information please login
www.oparck.com
www.sxdinggao.en.alibaba.com

PRODUCT DESCRIPTION

- **Power Post.** The Post that holds the Power Unit. Mount the Power Unit on one of the two Mounting Brackets.
- **Power Unit.** An electric/hydraulic unit that connects to an electric power source and then provides Hydraulic Fluid to the Hydraulic Cylinder that raises and lowers the Runways.
- **Flex Tubes.** Not shown. A flexible, black tube that attaches to an opening on the Powerside Runway on one end and to the Power Unit on the other end. Used for protecting the Return Line, Air Line, and Hydraulic Hose (and Microswitch Cable for Upper Platform) as they are routed to the Power Unit. One Flex Tube per Platform.
- **Upper Platform.** Can hold Vehicles up to 7,000 lbs.
- **Lower Platform.** Can hold Vehicles up to 9,000 lbs.
- **Powerside Runway.** On the same side as the Power Post (holds the Power Unit). The Powerside Runway has the Hydraulic Cylinder and the Cables under it. Same for both Platforms.
- **Offside Runway.** The other Runway. It does not have a Hydraulic Cylinder or Cables under it. Same for both Platforms.
- **Aluminum Decks.** Sits in between the two Runways. Protects any leakage from falling onto the Vehicle below. Two per Platform.
- **Safety Shutoff Bar.** Located on the underside of the Upper Platform. The Safety Shutoff Bar stops upward movement of the Lift. If you are raising a Vehicle on the Lower Platform and it hits the Safety Shutoff Bar, the Lift immediately stops moving.
- **Crossbeams.** Extra structural stability for your Lift. Two Crossbeams connect the Powerside Posts and another two connect the Offside Posts.
- **Crossbeam Brackets.** Holds the Crossbeams in place, two per Post. Brackets must face the inside of the Lift.
- **Drive-up Ramps.** The Upper Platform uses a longer set of Ramps, and the Lower Platform uses a shorter set of Ramps. Use them to drive onto and off of the Runways. Two per Platform.
- **Tire Stops.** Located at the Front of the Lift, Tire Stops prevent the Vehicle's Front Tires from going any further forward. Additionally, we recommend that you chock the Vehicle's Rear Tires. Two per Platform.
- **Safety Locks.** Once engaged, they hold the Runways in position, even if the power goes out or there is a leak in the Hydraulic Hoses. Your Lift has two columns of Safety Locks per post, spaced every four inches. This lets you lock the Runways at just the right height for what you want to do. This Lift also has a backup Slack Safety system; refer to About Safety Locks for more information. Only leave your Lift on the ground or engaged on a Safety Lock.
- **Platform Selector Valve.** Controls which Platform is in operation; only one Platform can be raised or lowered at a time.
- **Pushbutton Air Valve.** Moves the Safety Locks away from the Ladder so that they do not engage as you lower the Lift. Used to lower the Runways.
- **Ladders.** Pieces of steel that gets installed at the back of each Post; these are part of the Safety Lock system.



PP-17DH

MULTI-LEVEL PARKING LIFT



技术参数 Technical parameters

Model	PP-17DH
L×W×H	6121×2804×4010mm
Max. Lifting Height (upper platform)	3689mm
Max. Lifting Height (lower platform)	1783mm
Min Height	270mm
Overall length	6121mm
Inside column width	2552mm
Overall Width	4010mm
Platform Length	4775mm
Runway Width	482mm
Width between runway	1121mm
Upper platform capacity	7000lbs
Lower platform capacity	9000lbs

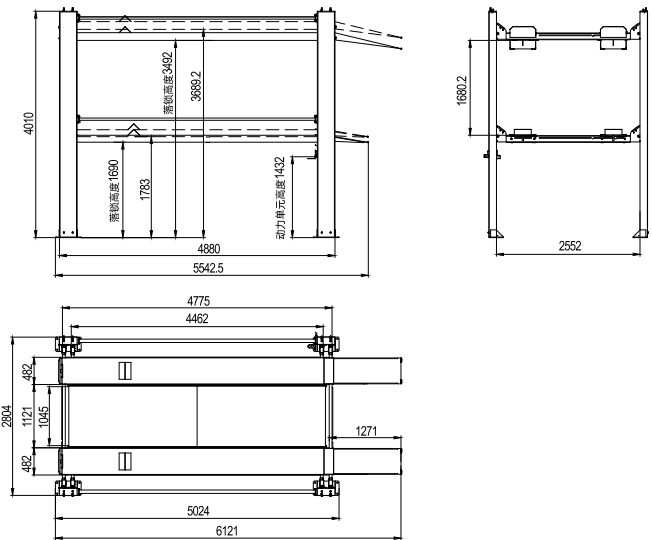

细节说明 Detail



Air cylinder for air release



Pulley and cable under upper main platform



Limit switch

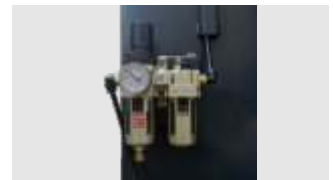

Oil-water separator

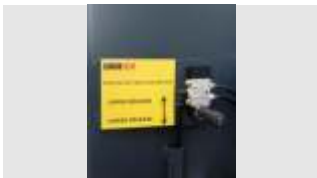

Air release device

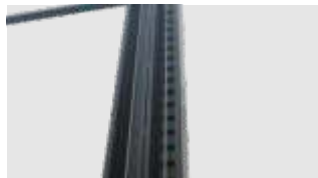

Lock ladder inside the column

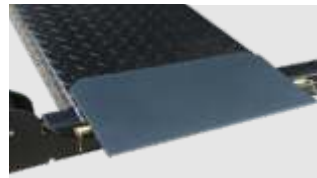

Stop running plate



Stop running plate

OPARCK

More information please login:
www.oparck.com www.sxdinggao.en.alibaba.com

SHAOXINGDINGGAOMECHANICAL EQUIPMENT CO., LTD.

NO.186 Mashan Road, Paojiang Industrial Zone, Shaoxing, Zhejiang, China
 TEL: 0086-0575-84623366 FAX: 0086-0575-84623331
 E-mail: lichao@dinggaomechanical.com



www.oparck.com



www.sxdinggao.en.alibaba.com